

BIKE POWER GENERATOR

OWNER'S MANUAL



STOCK NO. 454104

Phone: 802-425-3435

WWW.WINDSTREAMPOWER.COM

Table of Contents

| | |
|---|----|
| Product Description and Operating Instructions | 3 |
| Definition of System Components | 5 |
| Assembly | 6 |
| Prepare frame | 6 |
| Attach generator | 6 |
| Mount bicycle | 8 |
| Adjust friction drum | 8 |
| Connect to Power Pack or other battery | 9 |
| Other Useful Information | 12 |
| Battery Charging | 12 |
| Battery Voltages | 12 |
| Battery Connections | 13 |
| Safety Precautions | 13 |
| Mechanical Operation | 13 |
| Electrical Operation | 13 |
| Maintenance | 14 |
| Bicycle Tires | 14 |
| Generator Brushes | 14 |
| Equipment Return Policy | 15 |
| Conditions of Sale, Warranty and Shipping Information | 17 |

Product Description and Operating Instructions

You have purchased a system that harnesses a readily available source of renewable energy – Human Power. It is user-friendly, portable, and available whenever you need it. The power output is directly proportional to the effort of the person pedaling. The Bike Power Generator can be a valuable tool in teaching an appreciation of the power we often take for granted.



Windstream Bike Power Generator with Power Pack

Applications

- Emergency power generation and battery charging - land and marine.
- Exercise systems that do useful work generating power while exercising.
- Measurement of human power and endurance.
- Remote or off-grid power for 12-volt water pumps and small appliances.
- Independent radio or radiotelephone systems; emergency communications.
- Classroom projects and educational exhibits to demonstrate the physical effort required to generate electrical power.

The Bike Power Generator consists of a heavy steel frame holding a permanent magnet DC (direct current) generator. Your bicycle is attached to the frame and the rear tire makes contact with the friction drum that turns the generator shaft to create electrical power. The amount of electrical power that can be generated by the Bike Power Generator is determined by the energy available from the person pedaling.

Sustainable Power output

One of the most commonly asked questions is: How much power can a rider expect to produce from the Bike Power Generator? The average person can produce 100 to 150 watts sustainably. To achieve this, the Bike Power Generator has been designed with a generator

capable of sustaining 14 amps of **continuous** current and up to 20 amps of current for short periods of time (maximum 40 minutes). The average rider will charge at about 10 to 12 amps. The power output will be variable, based on the rpm.

To understand power output, multiply volts (V) x amps (A) = power (watts), for example: 12A x 12V = 144 watts. When used to charge a 12-volt battery, this allows for a **maximum but not continuous** power output of 300 watts at 15 volts, which is a fast charge of a 12-volt battery. To accurately measure the level of charge in any battery, it must rest for 15 minutes before taking the reading.

How long it will take to charge a 12-volt battery depends on the charging current produced by the rider and the amp hour (AH) rating of the 12-volt battery. For example, if the battery is rated at 20 amp hours and the rider is charging at 12 amps, it will take approximately two hours to recharge (20AH divided by 12A = 1.6666 hours). This calculation can be used for any size battery.

While the Bike Power Generator is capable of charging any 12V battery, we recommend a deep cycle battery with low amp hours. We strongly advise against using a 12V car battery. These batteries are not designed to be charged and discharged repeatedly. Also, an automotive battery holds at least 200 amp hours, which would take over 15 hours of pedaling, which would be difficult to achieve.

Windstream offers a custom Portable Power Pack (sold separately) that houses a deep cycle battery, an inverter, and the required Human Power connections to allow use with typical household appliances. The Power Pack provides a stable electrical current, which is important for DC and AC appliances.



Windstream Portable Power Pack

Certain DC appliances, such as DC lights or low power pumps or heaters, can be powered directly without the use of a battery, but it is extremely important to observe maximum voltage ratings to avoid damaging these appliances – you must monitor your output with a multimeter (sold in any electrical supply store) Windstream is not responsible for any damage to appliances that fail as a result of over voltage in DC direct applications.

Definition of System Components

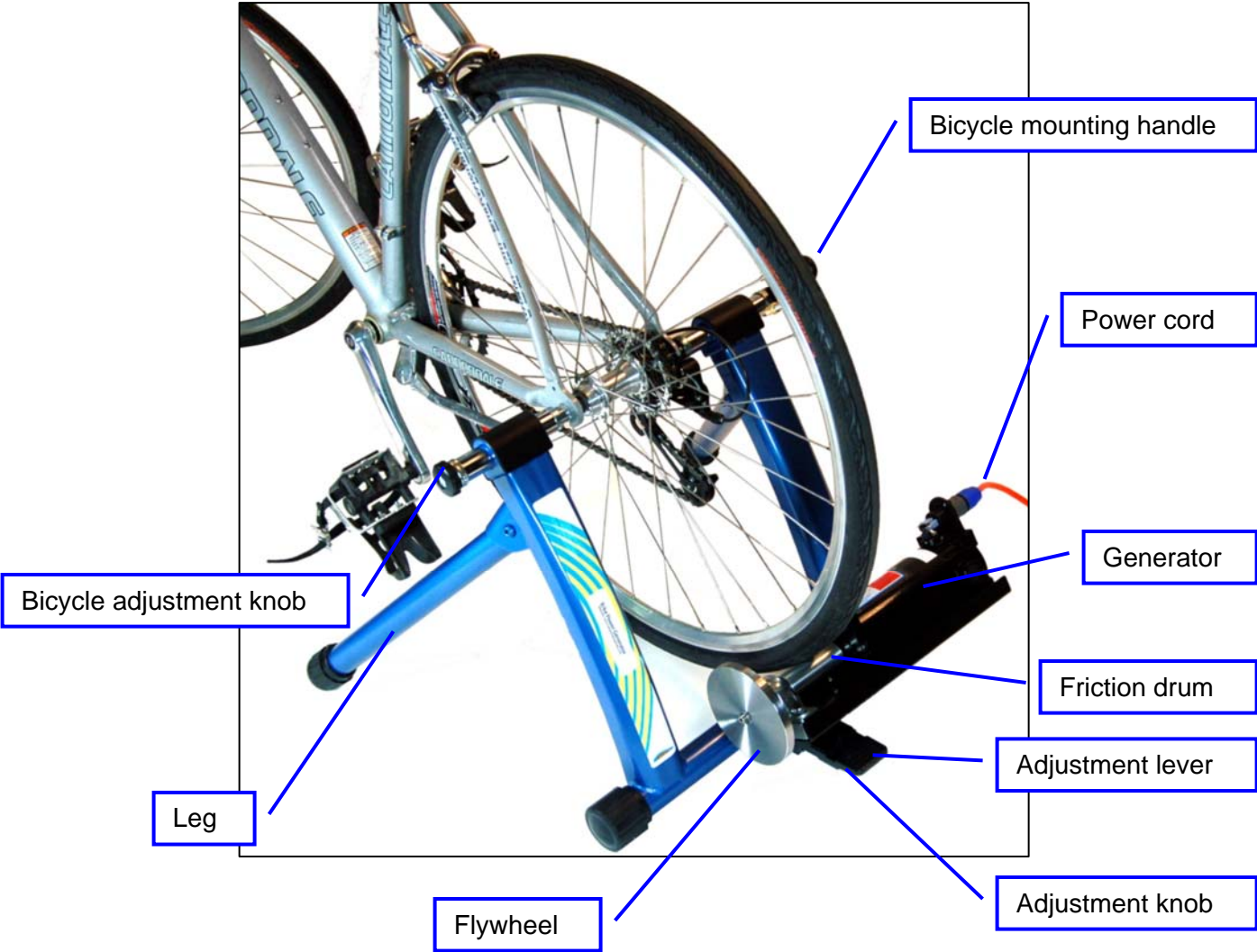

Assembly

Follow these easy steps to assemble your Bike Power Generator. Refer to the pictures at left and the Definition of System Components on page 4.

Prepare frame



1. Remove frame from packing foam.
2. Slide rubber feet onto legs before placing on a scratchable surface.

Attach generator



3. Remove black generator module from packing foam.
4. Adjustment lever is located on base of generator module. Unscrew nut and remove bolt to separate lever from generator.
5. Find the adjustment knob, located on bottom of adjustment lever. Check that adjustment knob is unscrewed all the way, so no screw threads are visible.



6. Place the Bike Power Generator frame so it is lying flat on a table or other surface with the mounting bracket facing up.
7. Hold the generator module and adjustment lever with one hand, carefully aligning the mounting holes.

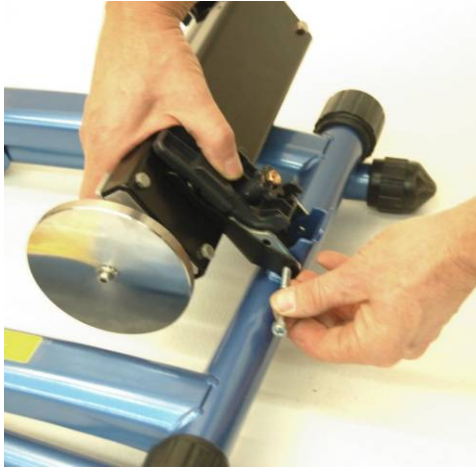

8. Align mounting holes on generator and adjustment lever with holes on frame mounting bracket.

9. Insert the bolt through all three sets of holes.

Note: Parts must be perfectly aligned for bolt to fit, so you may need to repeat this step a few times.

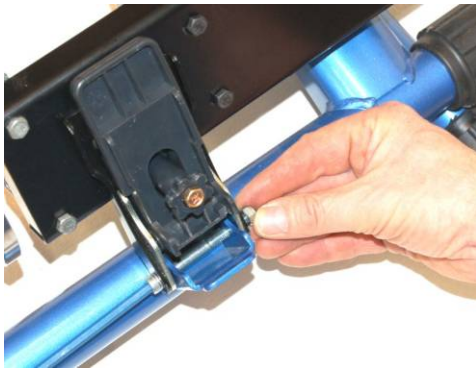

10. Tighten the nut with your hand.



11. Use the provided hex wrench, and a standard adjustable wrench (not provided) to tighten the nut.



12. Stand the frame upright, taking care to support the generator while you reposition the frame.

13. Unfold the legs, allowing the frame to stand on its own.

Mount bicycle



14. For best results, select a bicycle that is well maintained. Inflate tires to maximum pressure for most efficient power generation. Similarly, you will have better results with a smoother tire tread.
15. Turn bike mounting handle counterclockwise to loosen. Place your bicycle in frame and turn mounting handle clockwise to tighten.
16. Tire should be roughly centered on silver friction drum. If you need to adjust alignment of bicycle, the alignment knob is located opposite the bicycle mounting handle. Turn alignment knob clockwise to tighten and counterclockwise to loosen.

Adjust friction drum



Note: Friction drum should be tight to tire for best efficiency.

17. Hold generator module up so friction drum contacts tire. Turn adjustment knob, located under adjustment lever, clockwise until the screw is touching bottom of generator module.



18. Use your hand to press tire and friction drum together as tightly as you reasonably can. Continue tightening adjustment knob.

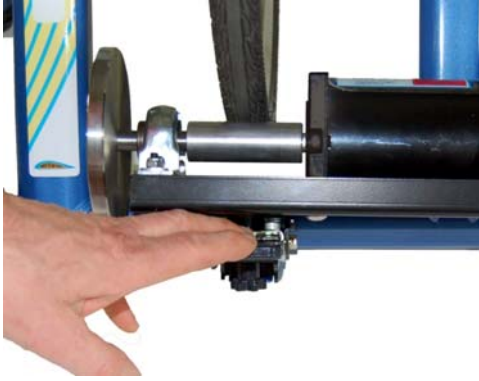

19. Push lever down until it clicks to complete adjustment.

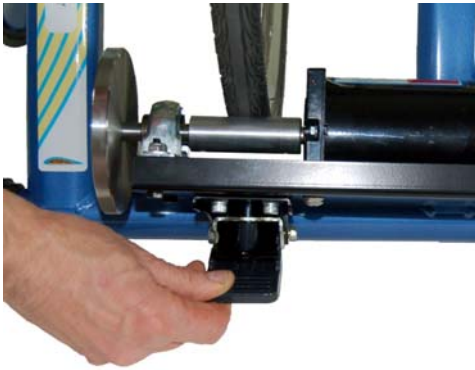

20. Lever is now locked in position.

Connect to Power Pack or other battery



21. Align tabs on power cord with grooves in port on generator.



22. Holding the blue part of the plug, insert and gently turn clockwise.



23. Grey collar will click into place to lock the plug.



24. The standard power cord has the same quick connector on both ends. You can connect it to the Power Pack using the same steps described above.

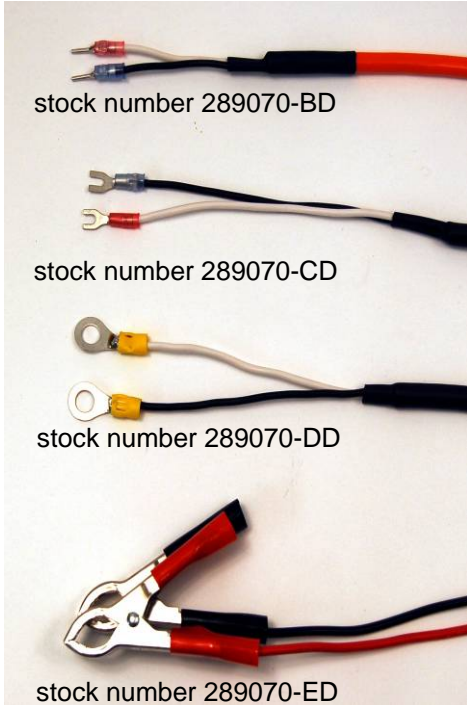

25. Pin connectors

26. Spade connectors

27. Ring connectors (5/16)

28. Plier-style clips



stock number 289070-FD

29. You may order the cable with bare wires. There are three bare wires – white (positive), black (negative) and green (not used – cut off).



30. All optional cables contain an in-line full wave bridge rectifier that prevents reverse current from running back into the Bike Power Generator and discharging the battery. It also prevents damage in case of accidental reverse hookup. Note: the diode box will become warm to the touch.



31. You are now ready to start generating your own power!

Other Useful Information

Battery Charging

The Bike Power Generator is designed for use with a deep cycle 12-volt battery, such as the type used in the Power Pack. A 12-volt battery actually reaches 12.5-13.8 volts when fully charged, and falls to about 11 volts before it is no longer able to power 12-volt DC or 120-volt AC appliances.

To charge a battery, a DC power source of a higher voltage than the battery is connected to the battery, positive to positive and negative to negative. As long as the charging source is of higher voltage than the battery, current will flow into the battery until it is fully charged.

If the voltage of the charging source is less than the battery voltage, current will not flow into the battery even though the charging source may be capable of supplying power. The Bike Power Generator will not deliver a charging current to a battery until the generator is turning fast enough to develop a voltage higher than that of the battery. Consequently, very little effort is required to start pedaling, but as soon as the generator voltage exceeds the battery voltage, a great mechanical resistance is felt as power begins to be transferred into the battery. As the battery becomes fully charged, the mechanical resistance decreases.

It is important not to overcharge the battery. Overcharging can cause the battery to heat up and possibly release hydrogen gas. This can damage the battery and create a hazardous condition.



The Power Pack has a built-in voltage indicator allowing you to monitor the charge status of the battery. If the overcharging LED is steadily on while you are pedaling, you must slow down or add more load to the output inverter to decrease the overcharge level of the battery.

If you are using the Human Power Generator with your own battery, monitor the input voltage to prevent overcharging. Be sure to verify the maximum charging voltage with the battery manufacturer. It is a good idea to have an ammeter and a voltmeter (or multimeter) to measure output and battery voltage with certainty.

Battery Voltages

While the Bike Power Generator is designed primarily to supply 12-volt circuits and to charge 12-volt batteries, it can also be used, without modification, to power 6-volt circuits and batteries. As with 12-volt batteries, be careful to avoid overcharging. A 6-volt battery reaches 6.3-6.8 volts when fully charged. Deep cycle batteries are best suited to this application as they are designed to withstand repeated charge and discharge cycles.

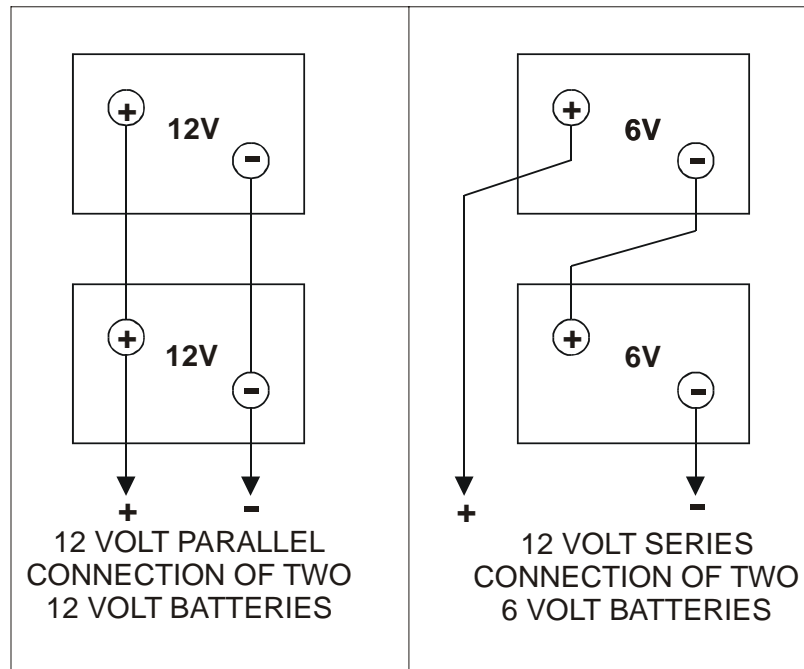

Battery Connections

Batteries can be connected in parallel (positive to positive and negative to negative) to increase storage capacity at the same voltage. They can also be connected in a series string (positive of one battery to negative of the next) to provide higher voltages, such as two 6-volt batteries combined in series to make a 12-volt battery. See diagram.





Safety Precautions

Mechanical Operation

-  Do not allow children to operate the Bike Power Generator unsupervised.
-  The generation of electricity requires a certain amount of physical exertion. People with health considerations should consult with their health care practitioners before engaging in strenuous pedaling.

Electrical Operation

-  As with any electrical device, use caution with the Bike Power Generator. Although the voltage generated is low, take care not to touch any exposed wires or to allow loose wires to touch each other.
-  Observe the polarity - positive and negative - of all connections.
-  Do not expose the Bike Power Generator to water or spray.

Maintenance

For the best results, use a well-maintained bicycle with the Bike Power Generator.

Bicycle Tires

Periodically check tire inflation. **Tires should be inflated to the maximum pressure for the most efficient generation.** Also, verify that the tire is very tight against the friction drum, as slippage will reduce efficiency and increase tire wear.

Generator Brushes

Inspect the generator brushes about once a year. Brush wear is proportional to use. The more you use the Bike Power Generator, the sooner you will need to replace the brushes. You can reasonably expect one set of brushes to last 3 to 5 years.

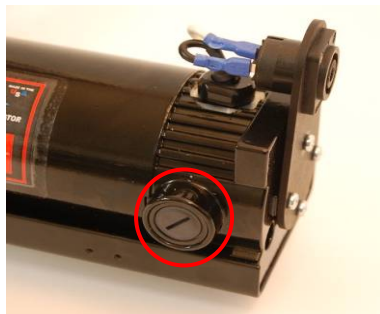

1. To inspect brushes, locate the brush caps on each side of the generator (2 total).

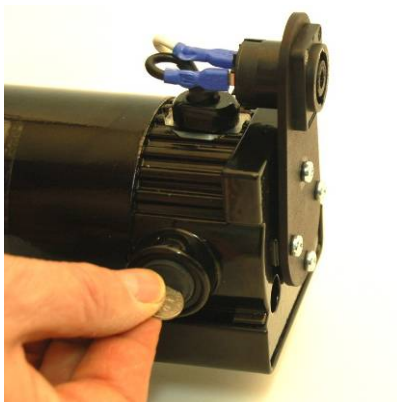

2. Use a coin to open each cap, and then carefully pull out each brush.

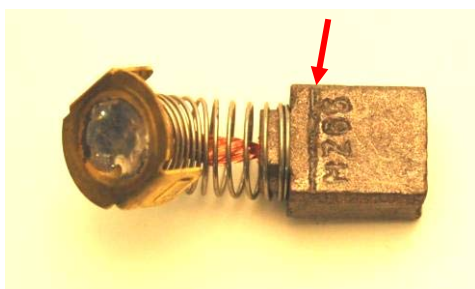

3. If the brushes are shorter than 3mm (about 1/8 in), indicated by the wear line near base of brush in the image at left; or if they are chipped or cracked, they should be replaced (Stock no. 443729).

Windstream Power, LLC

Equipment Return Policy

This Policy refers to any equipment or parts being returned to Windstream Power, LLC (WSP)

Either:

- Unused, within 30 days of purchase, for a full refund (excluding shipping) and may be subject to a 15% re-stocking fee depending on condition of product when returned.

Or

- For repair, both under warranty (see product warranty on Page 17) or out of warranty.

You must first contact WSP for a **Return Materials Authorization number (RMA)** before shipping any returns. Contact our service department at (802) 425-3435 to be assigned an RMA number.

- WSP reserves the right to refuse delivery of any equipment without an RMA number clearly displayed on the package(s).
- WSP reserves the right to refuse delivery of any equipment improperly packaged.
- Any equipment or parts shipped to WSP must be insured.

Any equipment or parts shipped to WSP must include the following documentation:

- WSP RMA/Repair Order form completed by customer, unless recorded by a WSP representative with whom you've spoken.
- Description of how the equipment was used.
- Reason for return.

RMA Number/Repair Order _____

Windstream Power LLC
445 Long Point Road
North Ferrisburgh, VT 05473
Phone 802-425-3435 Fax 802-425-2896

Date: _____

WSP Contact Name: _____

Customer Name and Address:

Cust. Contact Name: _____

Product Type _____

Phone Number: _____

Part Number: _____

Fax Number: _____

Serial Number: _____

How was the WSP product powered?

Human _____ Wind _____ Solar _____ Other _____

What was the power going out of the WSP product? AC _____ DC _____

To power what type of device? _____

What are the power requirements of the device being powered? _____

What other Windstream Power product(s) were also being used? _____

What other non-Windstream Power device(s) were also being used? _____

Reason for Return:

Signed: _____

THIS DOCUMENT MAY BE REPRODUCED

Conditions of Sale, Warranty and Shipping Information

1. PRICES

The prices shown on the published price lists are subject to change at any time, without notice.

The product list price includes all the most commonly ordered products. Other products, and variations on listed products, are also available. If you need any renewable energy products not listed, write or call for availability and prices.

Spare parts and component prices shown are on the individual parts list for each product, available upon request.

2. ORDERS

Orders must be prepaid, and can be accepted verbally or in writing by mail, fax, or e-mail. Confirmations, if requested, are sent promptly, indicating any special instructions or terms, factory lead time, and planned shipping date.

Changes or cancellation: orders for catalog products cannot be cancelled or changed after shipment. Special orders are noncancellable, and are subject to repricing if changes are requested.

3. DISCOUNTS

Discounts are available on catalog products to quantity purchasers, dealers, distributors, and manufacturers (OEM). For details, please contact the company.

4. PAYMENTS

Payments may be made by money order, MasterCard, Visa, American Express, interbank transfer (wire), or cash (factory pickup only). Payments by check are welcome, but are subject to normal bank clearance delays.

Payments for international orders may be made by U.S. dollar bank drafts or checks, payable on a U.S. bank; interbank transfers, or bank credit cards.

5. DELIVERY LEAD TIMES

Orders for goods in stock are normally shipped within five working days.

Goods not in stock at the time of order will be shipped within 30 days of order, failing which the customer will be advised.

Shipment dates of special orders are subject to arrangements made at the time of the order.

6. SHIPPING

Shipments within continental USA and Canada are normally made by prepaid UPS, freight or mail. Puerto Rico, Hawaii and Alaska are served by UPS (air service only) or mail.

Express same-day, next-day and second-day air delivery service is available on request. Factory pickup by customer may also be arranged.

International shipments are made by mail, air, or ocean freight; or air express, as requested.

7. SHIPPING CHARGES

Shipping and insurance are charged to the customer at cost.

Nominal handling charges may be included in shipping charges. Supplementary charges will be made for special packaging, such as export crating, or repackaging to comply with size, weight or dimensional weight restrictions.

8. INSURANCE

Shipments are normally insured up to the full invoice value, unless insurance coverage is waived at the customer's request.

The company will advise the customer before shipment in those instances where insurance is limited or unavailable.

The receiver of the shipment is responsible to inspect the goods upon arrival, and in the event of damage, to file a claim with the delivering carrier, as well as to notify Windstream.

In the case of a missing shipment, the customer must advise Windstream within thirty days of the expected arrival date. The company cannot be responsible for loss or damage claims made after expiration of the carrier's or insurer's period of liability.

9. GUARANTEE OF SATISFACTION

If a customer is not fully satisfied with a product purchased from Windstream, the product may be returned, and the company will refund the purchase price, subject to the following conditions:

A product returned for refund must be received within thirty days of the date of shipment, unused and in its original condition, duly authorized (see returns), freight prepaid, accompanied by a copy of the customer's invoice, and on inspection by the company confirmed to be in unused condition.

Shipping charges are not refundable. All return shipments must be insured, as the company cannot provide a refund if, on receipt, the goods have sustained any damage.

ALL SALES ARE FINAL THIRTY DAYS AFTER THE DATE OF SHIPMENT. NO REFUNDS CAN BE MADE AFTER THAT TIME.

10. PRODUCT WARRANTY

All products manufactured by Windstream are warranted against defects in materials or workmanship for one year from the date of purchase from the company.

This warranty does not cover damages due to shipping, improper handling or installation, accident, misuse, acts of nature, omitted maintenance or inspections called for in the owner's manual, or unauthorized service. The warranty also does not cover expenses incurred in the removal, shipping or reinstallation of the product.

Windstream shall not be liable for any incidental or consequential damage arising from the use of its products. Windstream makes no warranty of merchantability or fitness for any particular purpose of any of its products.

Products sold by Windstream but manufactured by others may be subject to longer or shorter warranties, and such warranty terms will supersede the general conditions shown on this page.

11. RETURNS

All returns must be securely packed and shipped freight prepaid, and must be marked with a return material authorization number (RMA #) which must be obtained by contacting the company. The customer's name, address, telephone number and written instructions must accompany any return shipment. Customers are advised to insure return shipments. ***Unauthorized returns will not be accepted.***

Goods returned for exchange or refund may be subject to restocking charges.

12. SERVICING

The company will repair or overhaul customer's equipment, shipped prepaid or delivered to the factory. Equipment is inspected and repair estimates are provided without charge, prior to performing the repair.

Warranty claims should be so indicated at the time of the return material authorization. Equipment subject to warranty will be specially inspected to determine eligibility for warranty service.

Repairs performed by company technicians are warranted for three months.

13. SPARE PARTS AND COMPONENTS

Spare parts, original equipment components and assembly drawings are available for all company-manufactured products, for use in maintenance, repairs, or for home construction – not for resale.

If components designed or manufactured by Windstream are to be used in the construction of equipment for resale, the buyer must obtain prior written permission or licensing from Windstream.